

POWER SOURCE

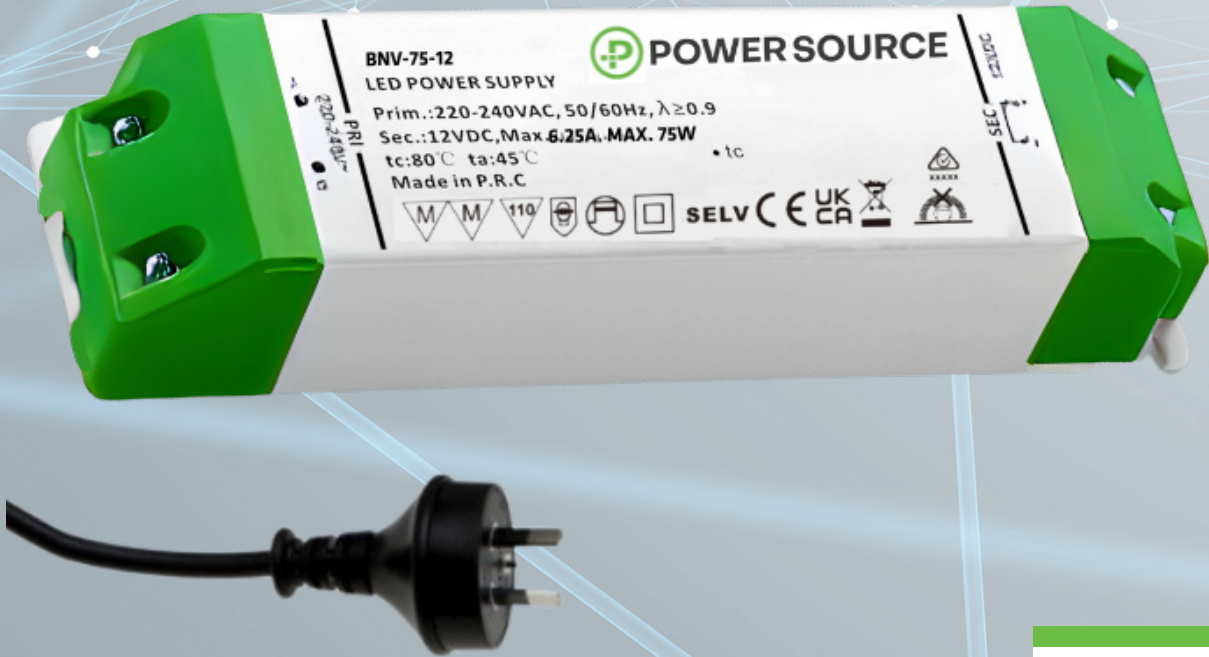

**3 YEAR
WARRANTY**

75W Non Dimmable LED Driver with PWM Output

Features of the: BNV-75 Series

-  Constant Voltage Output
-  AC Input Range: 220-240VAC
-  Protections:
 - Short Circuit
 - Over Load
 - Over Voltage
 - Over Temperature
-  Class II Power Supply
-  IP20 Design For Indoor Installation
-  Cooling by Free Air Convection
-  Factory Fitted Flex and Plug
-  Do not cover



SELV

Model		BNV-75-12	BNV-75-24
Output	DC voltage	12V	24V
	Voltage tolerance	±5%	
	Rated current	6.25A	3.125A
	Rated power	75W	
Input	Voltage range	220-240VAC	
	Frequency range	50-60HZ	
	Power factor	PF ≥0.9/240VAC/50HZ	
	Full load efficiency (Typ.)	89%	90%
	AC current (Max.)	<0.40A	<0.39A
	Leakage current	0.7mA	
	Inrush current	Cold Start <40A at 230 VAC	
Protection	Short Circuit	Hiccup mode, reset automatically after fault correction	
	Over load	Hiccup mode, reset automatically after fault correction. Exceed maximum rate load times 1.1~1.6	
	Over Voltage	1.5 times of rated output voltage	
	Over Temperature	IC detect TC = 115°	
Environment	Working TEMP.	-20~+45°C (refer to derating curve)	
	Working humidity	10-90%RH	
	Safety standards	AS/NZS 61347.2.13	
Safety & EMC	Withstand voltage	I/P-O/P: 3.75KVAC / 5mA. Max /60s	
	Isolation resistance	I/P-O/P: ≥10MΩ/500VDC/25°C	
	EMC emissions (Note 3.)	EN IEC 61000-3-2, Class C. EN55015	
Others	Net. weight	0.25KG	
	Size	170*44.5*28.2mm (L*W*H)	
Notes	<ol style="list-style-type: none"> The power supply is considered as a component that is operated in combination with final equipment. EMC performance could be affected by the complete installation. Original equipment manufacturers may need to conduct additional EMC testing and certification on the final equipment. Recommended loading range from 10% to 100%. Specifications are subject to change without prior notice. Contact ADM to confirm any critical parameters. 		

Mechanical Specification

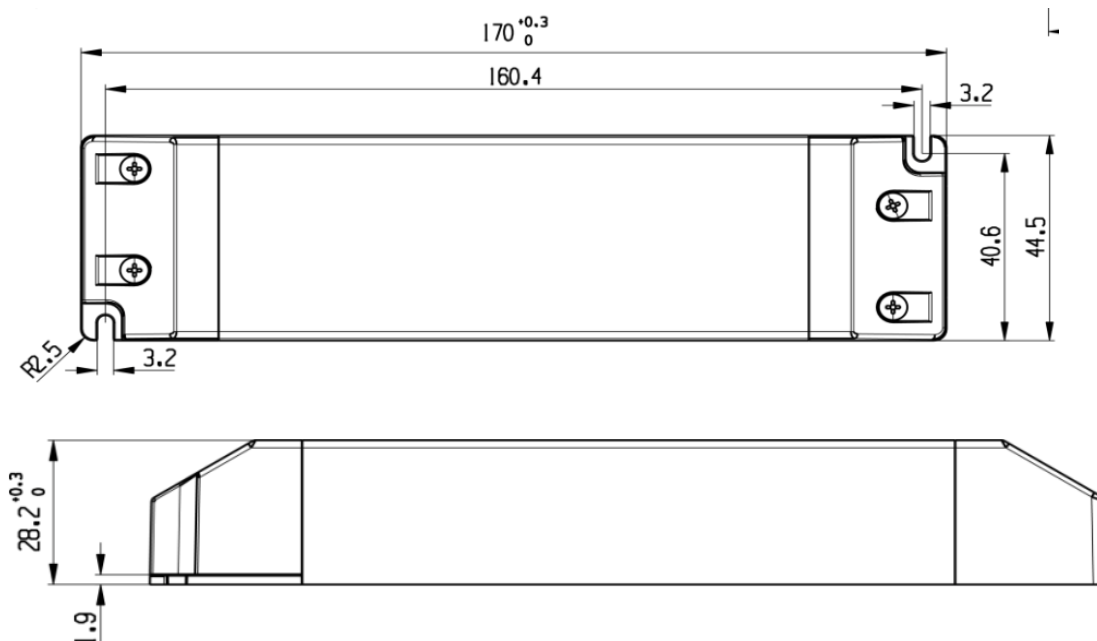

- Connect LED to LED driver via screw terminals under removable cover. Positive (LED+), Negative (LED-).
- Incorrect wiring could result in damage to the power supply, which is not covered by the warranty.
- Contact ADM with specific input, or output configuration requests.

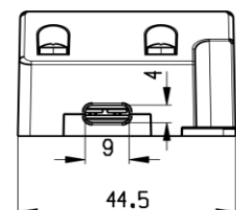

Connection Diagram

Single Driver Connection Diagram

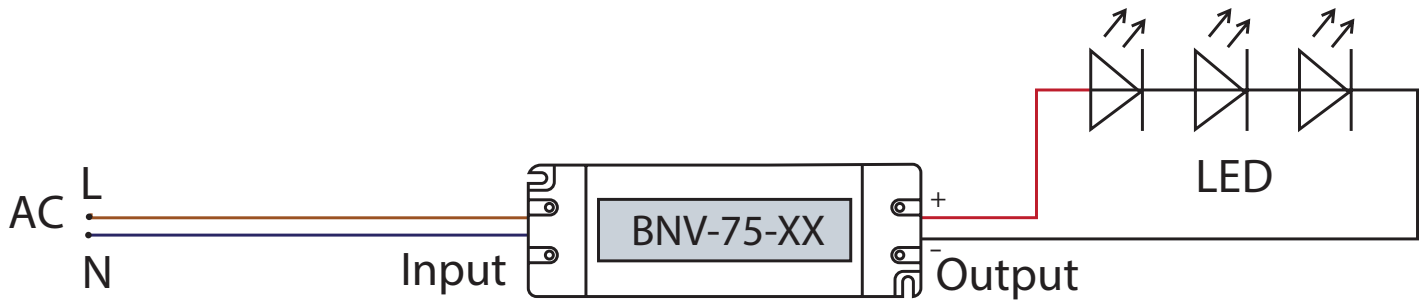

Multiple Driver Connection Diagram

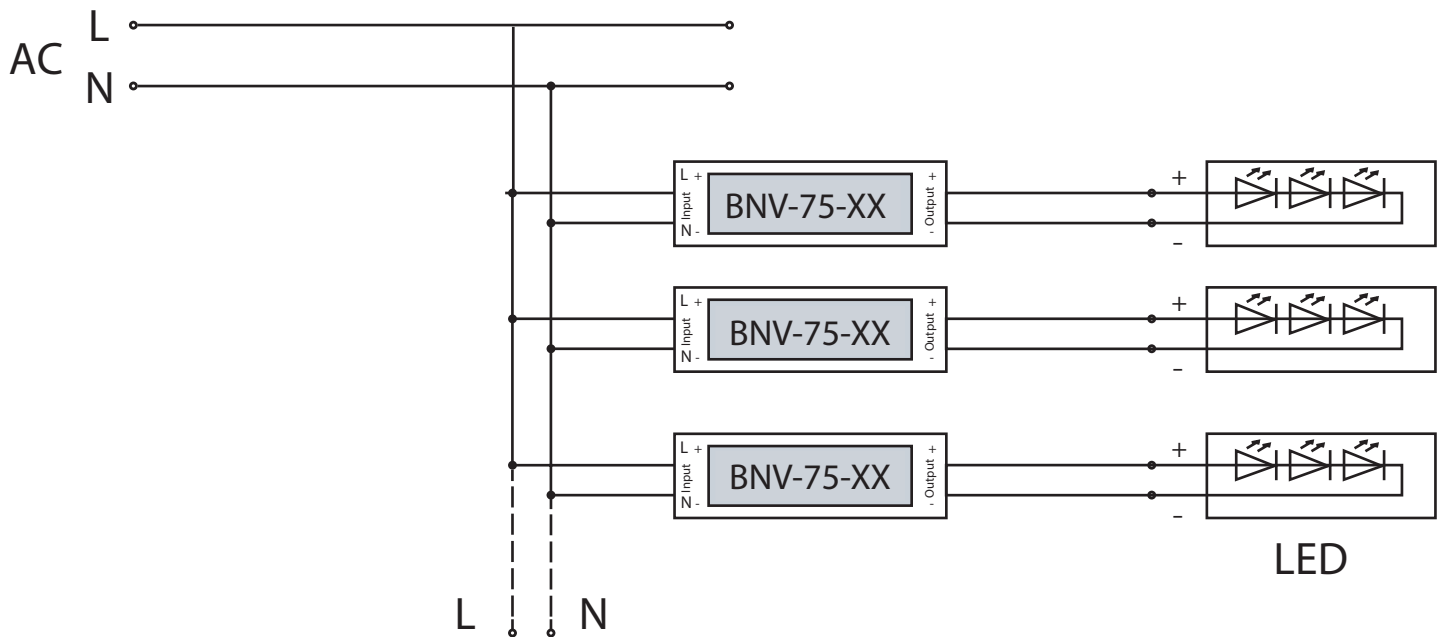

De-rating Curve

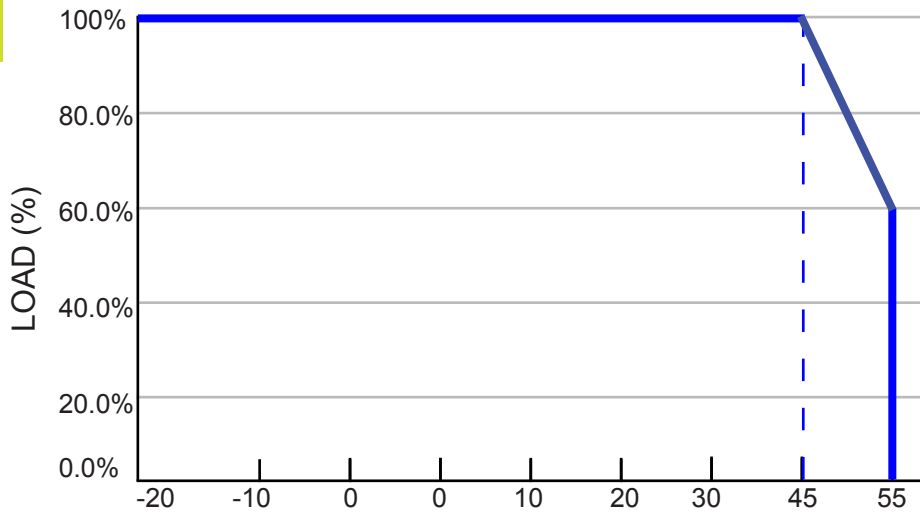

• If being used in higher ambient temperatures, ensure the load on the LED driver is de-rated in accordance with this chart. Failure to do so could lead to a failure, which is not covered by the warranty



Instruction:

- 1) This LED driver should be installed by a qualified electrician.
- 2) Please make sure the LED driver is installed with adequate ventilation around it to allow for heat dissipation.
- 3) Ensure that all wiring is correct before testing in order to avoid damage to the LED driver, or the LEDs.